

**Forest Park Crew, Inc.**  
**Board Meeting Minutes**  
**20 Nov 2024 @ 5:30pm (All American Steakhouse)**

**Establishment of Quorum**

Board Members: Lisa Rivera, Ruth Avelis, Elizabeth Green and Don Green  
Key Volunteers: Angie Jeffcoat, Tatjana D’Arcangelo

**Adoption of Board Meeting Minutes:**

Angie motioned to adopt, seconded by Ruth.

**Team Representatives Report:**

Student Reps Present: Rose Villareale, Leah Gregory

- The name chosen for the new 4+ is Medusa

**Old Business/Actions**

- Did Team Reps get log-in info for Instagram account? (Team Reps)
  - Yes, Dayle has access.
- Decision on attending Stotesbury (All)
  - Since no decision has been made regarding US Rowing, the recommendation is that we do not attend.
  - Another issue is the difficulty of the logistics.
  - Recommendation made to go every three years.
  - Motion made by Lisa to vote on not going this year. Seconded by Angie. Vote taken and all agreed to skip this year.
- Name for the new 4+ (Coach Mabeus)
  - The name chosen for the new 4+ is Medusa
- Provide Jolene with Sponsorship information to post on Crew website. (Ruth)
  - Complete.
- Create a PowerPoint for instructions on how to use RaiseRight. (Ruth)
  - Will work on a PowerPoint for Spring Presentation.
- Provide an end of season accounting and forecasted budget for this year. (Ruth)
  - Complete - Provided at meeting.
- Status on set up of new email accounts (Lisa, Ruth, Angie & Tatjana)
  - Lisa and Tatjana still need to set up. **(Open Action)**
- Will Activity buses be available for Spring Crew? (Lisa & Mia Simpson)
  - Yes, Activity buses will be available.
- Board approved the purchase of two sets of new oars

**Coach’s Report:**

Coaches Present: MaryPat Mabeus and Kerry Golden

- VASRA break up with US Rowing and Insurance
  - How will this affect the decision to go to Stotesbury (see above)
- James River Sprints on 26 April or Al Urquia Regatta?
  - Al Urquia is the last regatta on the Occoquan before States.
  - Coaches recommend we do the James River instead as we are not going to Stotes.
- Winter Conditioning
  - We have 23 or 25 rowers registered, but only have 6 Blue Cards and Physicals.

**Forest Park Crew, Inc.**  
**Board Meeting Minutes**  
**20 Nov 2024 @ 5:30pm (All American Steakhouse)**

- Coaches met at the Boathouse to realign the boats on racks. Spoke to Ken, who said not to buy our own insurance. They will buy the insurance that will cover everyone.
- PWCS system cautious on communication with students. Any email sent, must have the parents included.
  - We might want to look into using a Messaging App instead of counting on emails. One of the teams uses **Spond** which is a Free Sports Team Management App.

**Board Member Reports:**

**President (Acting) – Lisa Rivera**

- VASRA updates
  - No progress has been made regarding Safe Sport jurisdictional issue- If they do not change, we cannot remain members of US Rowing per county athletic directors.
  - Waiting on a decision from SRAA and a vote from them.
  - We need to look at additional insurance - Leonard was recommended. We need to get a quote from them.
  - I am assuming might pursue a group policy. I will check with Ken in this months meeting.
- Confirmed Spring Registration dates with school and times enclosed cafeteria will be available.
- Results from Rent-A-Rower
  - We had 25 kids participate and raised \$3,070, \$550 of that will go towards registration fees for students who requested that instead of hours.
- We need to announce that scholarships though Occoquan Boat Club open mid-December for any potential members that will need it, that way it can be approved before registration.
  - Complete. Has been posted to website.

**1<sup>st</sup> VP (Fundraising) – Ruth Avelis (Acting)**

- Spirit Nights
  - Five Guys (Fortuna Plaza) – Earned \$463.16
  - Panera (Fortuna Plaza) – Earned \$74.49
  - All American Steakhouse – 20 NOV, All day (last year raised 700)
  - Brothers – 04 DEC, 4-8PM (need to confirm); need to print flyer to get credit
  - Giorgio’s – TBD JAN; waiting to hear back from the owner
- Updates to RaiseRight – Email sent out to families 18 NOV
- Alamo Draft House Tickets for Fundraising
  - Lisa motioned to vote on purchasing 150 tickets to be used for fundraising. Angie seconded. Board voted and all agreed.
- Sponsorship information on the team website – need Jolene’s help to add it to “About Us” drop down menu
- Sponsorship leads – Ask rowers/families for 5-10 businesses they patron; fundraising member will make sponsorship pitch. If successful, propose a tuition credit of \$10 for successful leads.
  - Angie motioned to vote on asking for sponsorships. Elizabeth seconded. Board voted and all agreed.
- Fundraising plan for 2024-25

**Forest Park Crew, Inc.**  
**Board Meeting Minutes**  
**20 Nov 2024 @ 5:30pm (All American Steakhouse)**

**2<sup>nd</sup> VP (Registration) – Lisa Rivera**

•

**Treasurer – Ruth Avelis**

- Financials – As of 19 NOV 2024
  - Checking account - \$5,862.46
  - Money Market account - \$78,322.70
  - These totals do not include all money collected for Winter Conditioning and Rent-a-Rower
- Income
  - Five Guys - \$463.16
  - Panera - \$74.49
  - RaiseRight - \$27.53 (SEP)
  - Petite Plume - \$118.00
  - Winter Conditioning - \$150.00 (does not include Regatta Central payments)
  - Rent-a-Rower - \$2,980.00 (not the complete total)
- Donations
  - Diana Smith – \$20.00
  - Dr. Jeffrey Wynn - \$50.00
- Paid Expenses
  - Debit Card
    - Virginia State Corporate Commission (Reinstatement/Annual Report) - \$10.00
    - Brothers (Rent-a-Rower food) - \$96.80
  - Zelle transfer
    - Kerrie Golden reimbursement for Homecoming decorations - \$184.61
    - Don Green reimbursement for oars, motor, flag, binoculars, locks and shed light - \$5,000.00
  - Checks
    - Check #2661 Don Green for oars, motor, flag, binoculars, locks and shed light - \$6,228.97
- Upcoming Expenses
  - Winter conditioning shirts
- Other
  - Nothing to report

**Secretary – Elizabeth Green**

- Need to create a Winter Conditioning Google Group
  - Completed.

**Director of Maintenance – Don Green (Acting)**

- Ordered the repair parts for Launch Motor #4 –
  - This motor has been out of commission since April 24 Cost of parts was \$242.70

**Forest Park Crew, Inc.**  
**Board Meeting Minutes**  
**20 Nov 2024 @ 5:30pm (All American Steakhouse)**

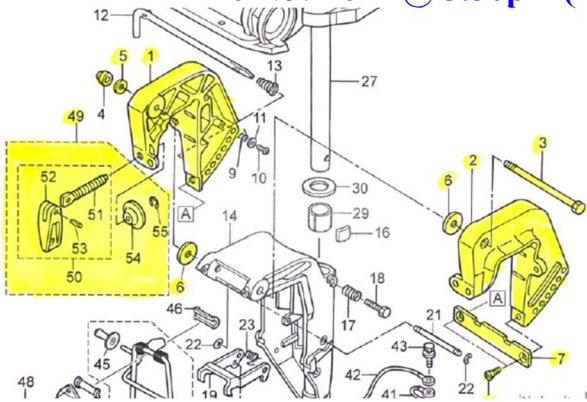

- Cut up Old Oars found in the Boathouse Loft area
  - We now have (17) Senior Trophy Blades for end of Season Awards
- Working on Estimate to Re-Furbish the shell Trailer
  - Estimate for new Decals was \$305.30
  - Body Shop used for last re-furbish is no longer in business.
- Evaluating how we will fit into the new storage configuration at the Oxford boat house after the new lockers and loft configuration is complete.
  - New Locker will be 2' Deep, 4' Wide and 6.5' High.
    - This is a much smaller space then we had before.

**Director of Operations – Don Green**

- We purchased several “Capital Improvement” items for the 2025 Season
  - \$ 256.89 Two Pair of Binoculars
  - \$. 2,407.14 New Outboard Launch Motor Tohatsu 9.8hp
  - \$. 50.04 New Locks for (Chuck Wagon, Shed at School, Storage Locker Boat House)
  - \$. 31.29 Auto Sensing Solar Light for inside the shed at school
  - \$. 8,211.20 Purchased 16 New Sweep Oars from Concept-2
  - \$ 272.42 Purchased New Sail Flag for use at the point
  - \$ **11,228.97** Total Cost of Capital Improvements
- Finish Line Repair determined the “Zeus” was totaled. Leonard Insurance approved their assessment, and the estimated pre-accident value of the Zeus was determined to be \$3000. Leonard Insurance has approved the claim for \$3000 minus our \$250.00 deductible and will send FP-Crew a check for \$2750.00. I have requested the Check be made out to “Forest Park Crew Inc.” and mailed to the Club PO Box in Dumfries.
  - The \$250.00 deductible will be paid by PWRC since the boat was being used by them when the damage occurred. We need to work with PWRC President Kerrie Golden to recoup this money.
  - **TOTAL REVENUE TO THE CLUB FOR THIS CLAIM IS \$3000.00**
- Working with Mr. Bricker for approval to provide ground protection for in front of the shed.
  - Depending on Cost I would propose doing just Option # 1 – but if we can get the rock at a good cost then I would recommend doing both Option # 1 and #2 of below.
  - I have sent the below diagram to Mr. Bricker for school approval to move forward, which was approved.

**Forest Park Crew, Inc.  
Board Meeting Minutes  
20 Nov 2024 @ 5:30pm (All American Steakhouse)**

- Lisa motioned to vote on spending up to \$600 for the rock. Angie seconded. Board voted and all agreed.

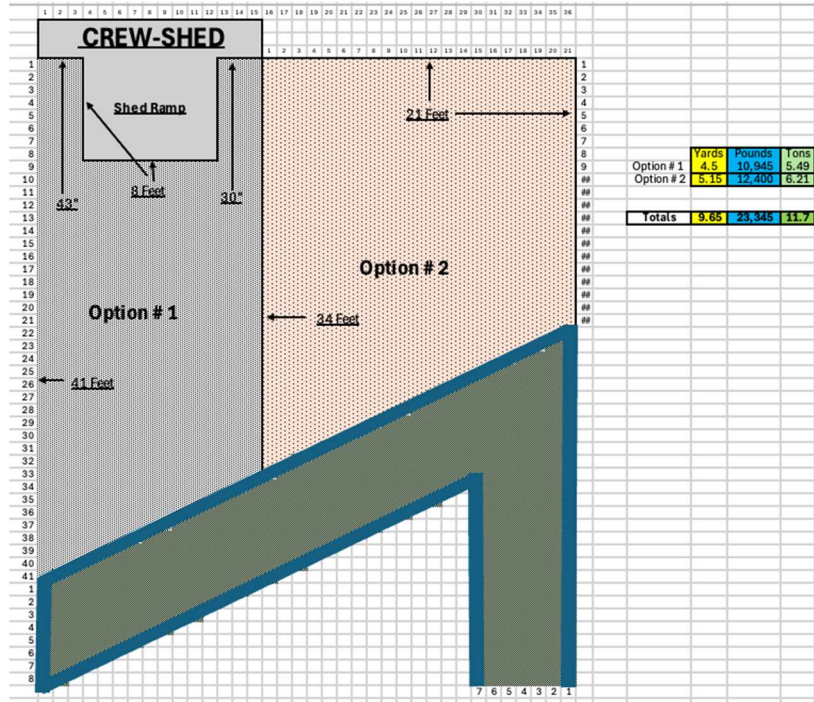

**Key Volunteer Position Coordinator Reports:**

**Uniform/Spirit wear Coordinator: Angie Jeffcoat**

- Winter Conditioning shirt will be designed by Rose. Rose will deliver design to Angie by Dec 1<sup>st</sup>.  
(Action – Rose)

**Website Coordinator: Jolene Edwards**

- Worked with Nexcess to make a change to the email records so emails from fpcrew.org are authenticated by Google and do not go to spam folders.

**Breakfast/Food Coordinator: Tatjana D’Arcangelo**

- Shopping for new Tupperware.

**Next Meeting:**

- Thursday, December 12<sup>th</sup> at 7:00pm via Zoom